



POWERING INNOVATION THAT DRIVES HUMAN ADVANCEMENT

© 2025 ANSYS, Inc. or its affiliated companies
Unauthorized use, distribution, or duplication is prohibited.

Getting Started with EMIT - Tutorial 1



ANSYS, Inc.
Southpointe
2600 Ansys Drive
Canonsburg, PA 15317
ansysinfo@ansys.com
<https://www.ansys.com>
(T) 724-746-3304
(F) 724-514-9494

Release 2025 R1
January 2025

ANSYS, Inc. and
ANSYS Europe,
Ltd. are UL
registered ISO
9001:2015 com-
panies.

Copyright and Trademark Information

© 1986-2025 ANSYS, Inc. Unauthorized use, distribution or duplication is prohibited.

ANSYS, Ansys Workbench, AUTODYN, CFX, FLUENT and any and all ANSYS, Inc. brand, product, service and feature names, logos and slogans are registered trademarks or trademarks of ANSYS, Inc. or its subsidiaries located in the United States or other countries. ICM CFD is a trademark used by ANSYS, Inc. under license. All other brand, product, service and feature names or trademarks are the property of their respective owners. FLEXIm and FLEXnet are trademarks of Flexera Software LLC.

Disclaimer Notice

THIS ANSYS SOFTWARE PRODUCT AND PROGRAM DOCUMENTATION INCLUDE TRADE SECRETS AND ARE CONFIDENTIAL AND PROPRIETARY PRODUCTS OF ANSYS, INC., ITS SUBSIDIARIES, OR LICENSORS. The software products and documentation are furnished by ANSYS, Inc., its subsidiaries, or affiliates under a software license agreement that contains provisions concerning non-disclosure, copying, length and nature of use, compliance with exporting laws, warranties, disclaimers, limitations of liability, and remedies, and other provisions. The software products and documentation may be used, disclosed, transferred, or copied only in accordance with the terms and conditions of that software license agreement.

ANSYS, Inc. and ANSYS Europe, Ltd. are UL registered ISO 9001: 2015 companies.

U.S. Government Rights

For U.S. Government users, except as specifically granted by the ANSYS, Inc. software license agreement, the use, duplication, or disclosure by the United States Government is subject to restrictions stated in the ANSYS, Inc. software license agreement and FAR 12.212 (for non-DOD licenses).

Third-Party Software

See the legal information in the product help files for the complete Legal Notice for Ansys proprietary software and third-party software. If you are unable to access the Legal Notice, please contact ANSYS, Inc.

Conventions Used in this Guide

Please take a moment to review how instructions and other useful information are presented in this documentation.

- Procedures are presented as numbered lists. A single bullet indicates that the procedure has only one step.
- Bold type is used for the following:
 - Keyboard entries that should be typed in their entirety exactly as shown. For example, “**copy file1**” means you must type the word **copy**, then type a space, and then type **file1**.
 - On-screen prompts and messages, names of options and text boxes, and menu commands. Menu commands are often separated by greater than signs (>). For example, “click **HFSS > Excitations > Assign > Wave Port.**”
 - Labeled keys on the computer keyboard. For example, “Press **Enter**” means to press the key labeled **Enter**.
- Italic type is used for the following:
 - Emphasis.
 - The titles of publications.
 - Keyboard entries when a name or a variable must be typed in place of the words in italics. For example, “**copy filename**” means you must type the word **copy**, then type a space, and then type the name of the file.
- The plus sign (+) is used between keyboard keys to indicate that you should press the keys at the same time. For example, “Press Shift+F1” means to press the **Shift** key and, while holding it down, press the **F1** key also. You should always depress the modifier key or keys first (for example, Shift, Ctrl, Alt, or Ctrl+Shift), continue to hold it/them down, and then press the last key in the instruction.

Accessing Commands: *Ribbons*, *menu bars*, and *shortcut menus* are three methods that can be used to see what commands are available in the application.

- The *Ribbon* occupies the rectangular area at the top of the application window and contains multiple tabs. Each tab has relevant commands that are organized, grouped, and labeled. An example of a typical user interaction is as follows:

"Click **Schematic > Line**"



This instruction means that you should click the **Line** command on the **Schematic** ribbon tab. An image of the command icon, or a partial view of the ribbon, is often included with the instruction.

- The *menu bar* (located above the ribbon) is a group of the main commands of an application arranged by category such File, Edit, View, Project, etc. An example of a typical user interaction is as follows:

"On the **File** menu, click the **Open Examples** command" means you can click the **File** menu and then click **Open Examples** to launch the dialog box.

- Another alternative is to use the *shortcut menu* that appears when you click the right-mouse button. An example of a typical user interaction is as follows:

"Right-click and select **Assign Excitation> Wave Port**" means when you click the right-mouse button with an object face selected, you can execute the excitation commands from the shortcut menu (and the corresponding sub-menus).

Getting Help: Ansys Technical Support

For information about Ansys Technical Support, go to the Ansys corporate Support website, <http://www.ansys.com/Support>. You can also contact your Ansys account manager in order to obtain this information.

All Ansys software files are ASCII text and can be sent conveniently by e-mail. When reporting difficulties, it is extremely helpful to include very specific information about what steps were taken or what stages the simulation reached, including software files as applicable. This allows more rapid and effective debugging.

Help Menu

To access help from the Help menu, click **Help** and select from the menu:

- **[product name] Help** - opens the contents of the help. This help includes the help for the product and its *Getting Started Guides*.
- **[product name] Scripting Help** - opens the contents of the *Scripting Guide*.
- **[product name] Getting Started Guides** - opens a topic that contains links to Getting Started Guides in the help system.

Context-Sensitive Help

To access help from the user interface, press **F1**. The help specific to the active product (design type) opens.

You can press **F1** while the cursor is pointing at a menu command or while a particular dialog box or dialog box tab is open. In this case, the help page associated with the command or open dialog box is displayed automatically.

Table of Contents

Table of Contents	Contents-1
1 - Introduction	1-1
Key Concepts	1-1
Project Configuration	1-1
2 - Add Radios to an EMIT Design	2-1
3 - Define Radio Bands and Samplings	3-1
Band Definition	3-1
Sampling Definition	3-6
4 - Modify Radio Channels	4-1
5 - Antenna Coupling	5-1
6 - Run the Simulation	6-1
7 - Add a Filter for Interference Mitigation	7-1

1 - Introduction

The focus of this tutorial is to introduce the user to transmitter (Tx), receiver (Rx) and transceiver (RT) models in EMIT by building a simple 1-Tx/1-Rx scenario. The simulation will be run using a fixed value for the antenna-to-antenna coupling and the resulting EMI margin examined. An interference will be identified and mitigated via the addition of a filter.

Key Concepts

- Add Radios to an EMIT design
- Define Tx and Rx Bands
- Run a 1-on-1 simulation
- Interpretation of results
- Mitigation using a filter

Project Configuration

A pictorial representation of the scenario we will analyze is shown below. A single Tx and Rx operating at different frequencies are evaluated for interference. The antenna-to-antenna coupling in this tutorial will be modeled using a fixed, frequency-independent value. The Tx is operating at a frequency of 50 MHz and a peak power level of 40 dBm. The Rx is tuned to 500 MHz and the in-channel susceptibility is -100 dBm.

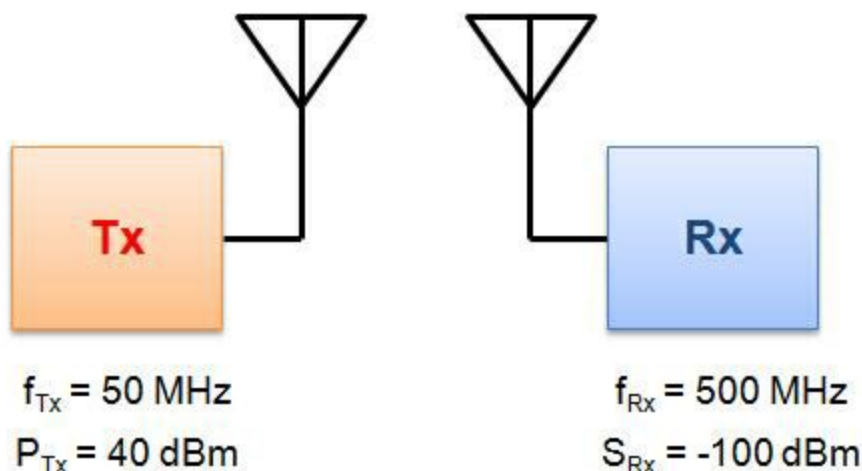

2 - Add Radios to an EMIT Design

Before starting the tutorial, we will change the units used in EMIT to MHz, to better suit the frequency range that we will be using in the tutorial. To do so, select **General Options** from the right side of the ribbon area under the Desktop tab, shown below.



In the **Options** window, select EMIT from the list of categories, and then under Frequency select MHz from the drop-down options. Click **OK** to save the change.

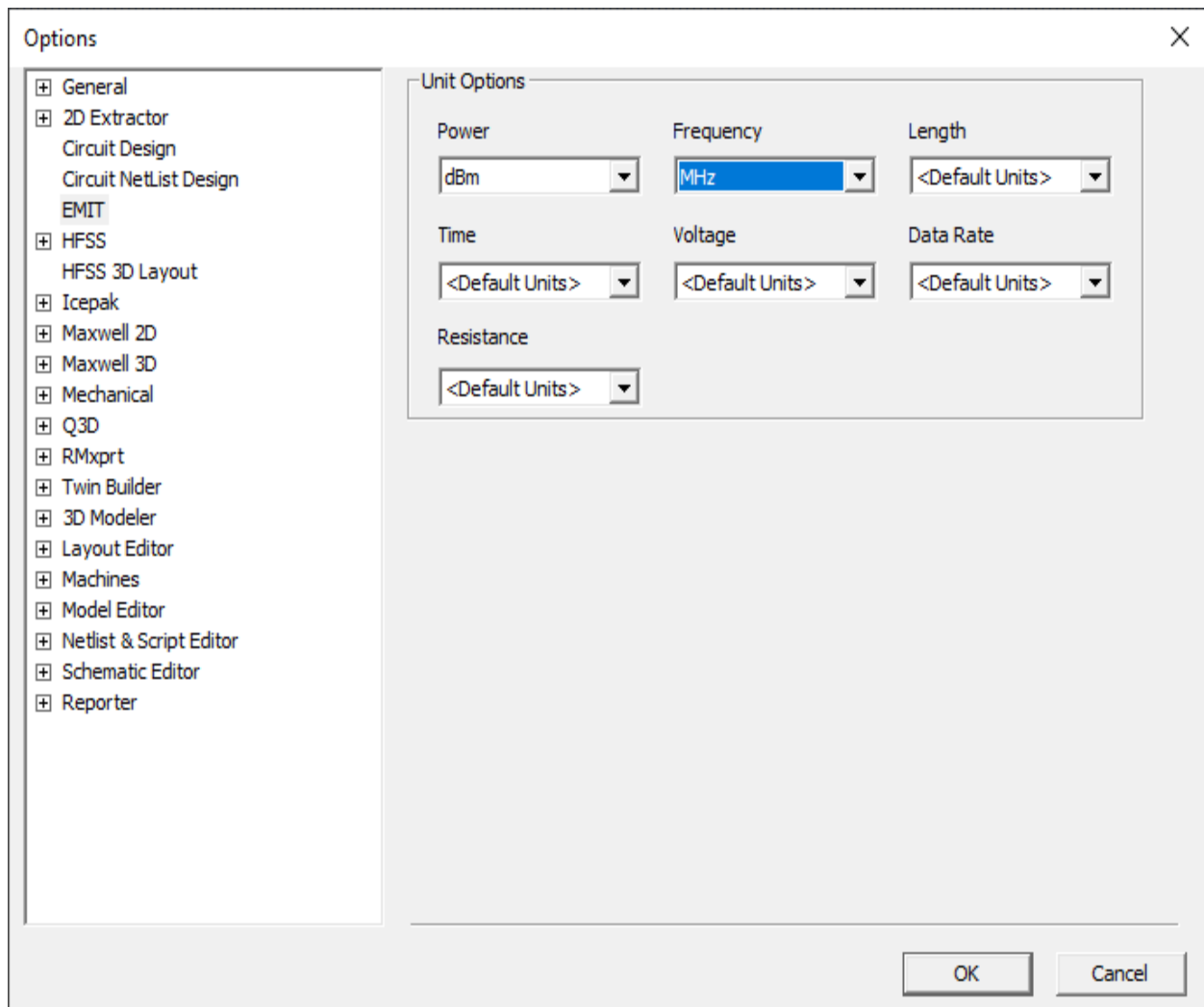

Getting Started with EMIT - Tutorial 1

If you do not already have a new project open, create a new project by clicking **New** in the ribbon area under the Desktop tab.

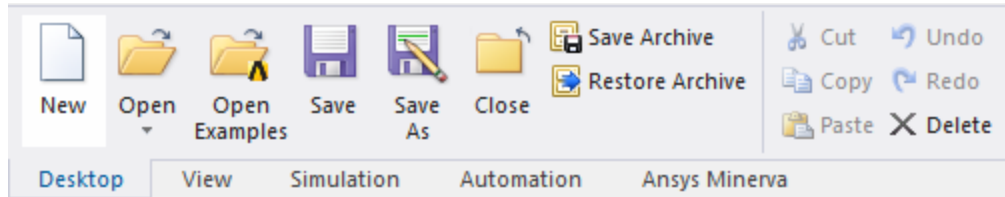

To add an EMIT Design to the new project, select **EMIT** from the ribbon area under the Desktop tab. This can also be done by right-clicking the project in the Project Manager window and selecting **Insert > Insert EMIT Design**.



Save the project as "Tutorial 1" by clicking the **Save** icon in the ribbon area, shown below. Save this to a folder somewhere in your user directory (as opposed to the EMIT installation directory, which is read-only).

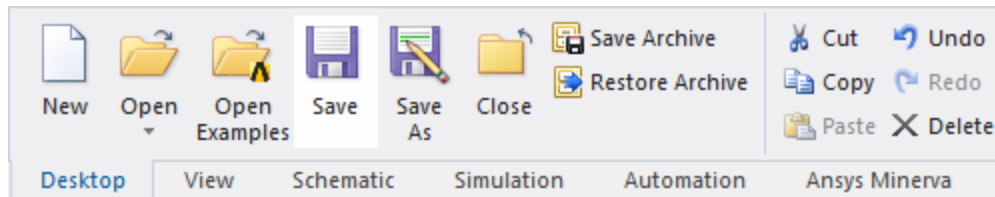

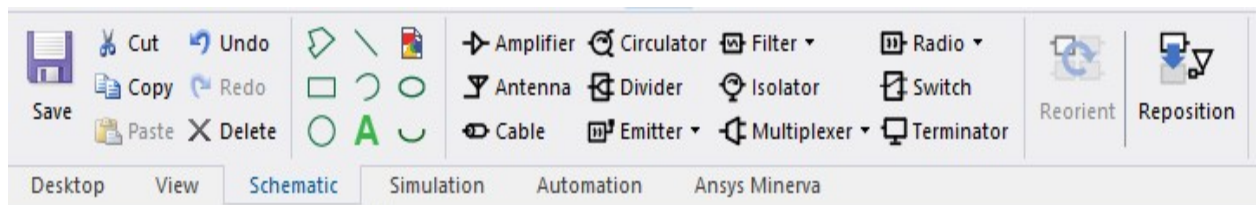

This tutorial uses two radios: a transmitter (Tx) and a receiver (Rx). To add radios to the design, build them from the components found in the Schematic tab of the ribbon area, shown below.



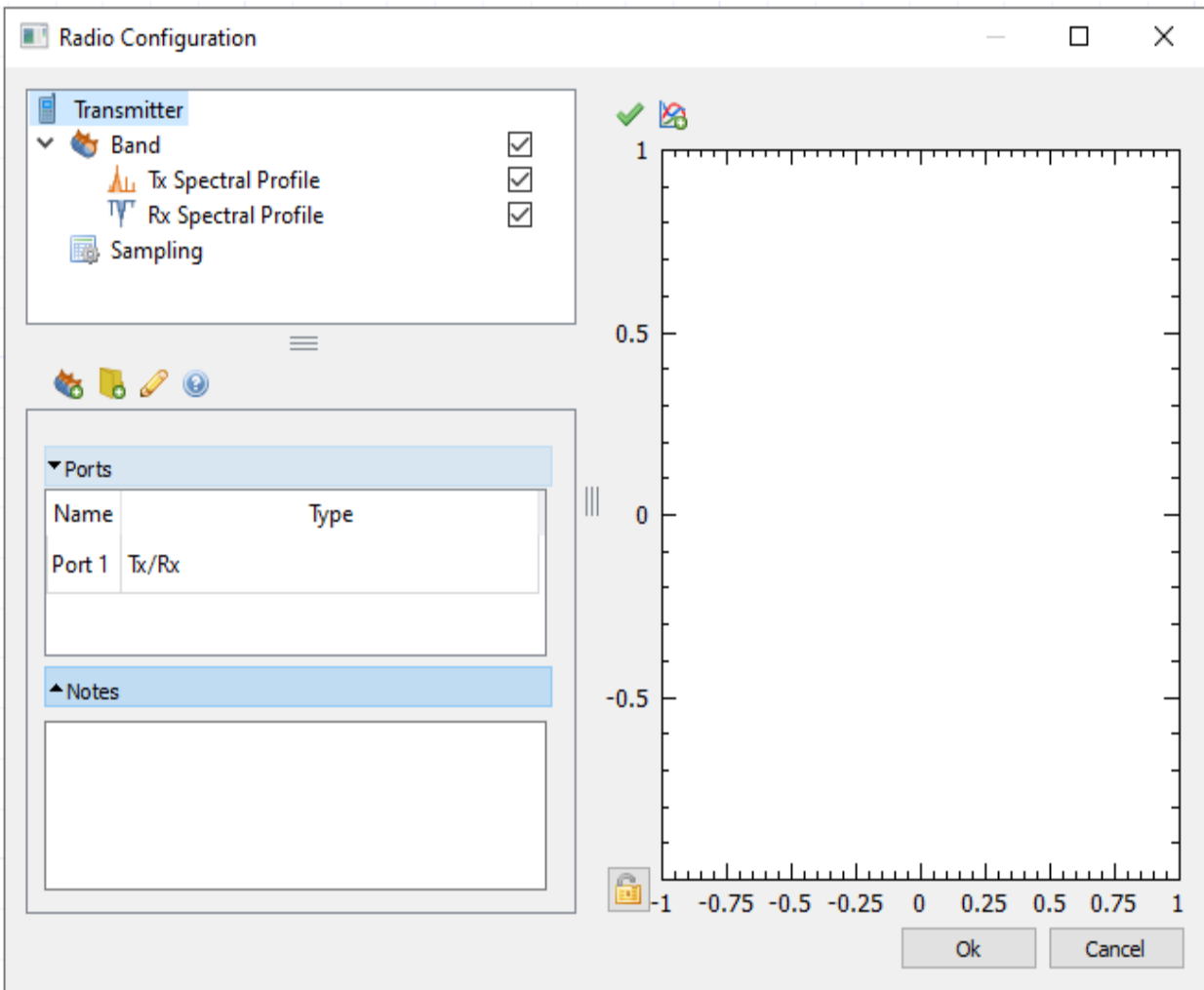

To add a new radio, click on the Radio icon () in the ribbon area and select New Radio. Double-click on the new radio component created in the schematic, or right-click and select **Configure**, to open its Radio Configuration window. In the top left of this window, you can find the node tree for the new radio. Right-click on the node titled New Radio and select **Rename**. Name

this radio *Transmitter*. The resulting **Radio Configuration** window is shown below. Click **OK** to close the window, which also automatically saves the changes to the design.

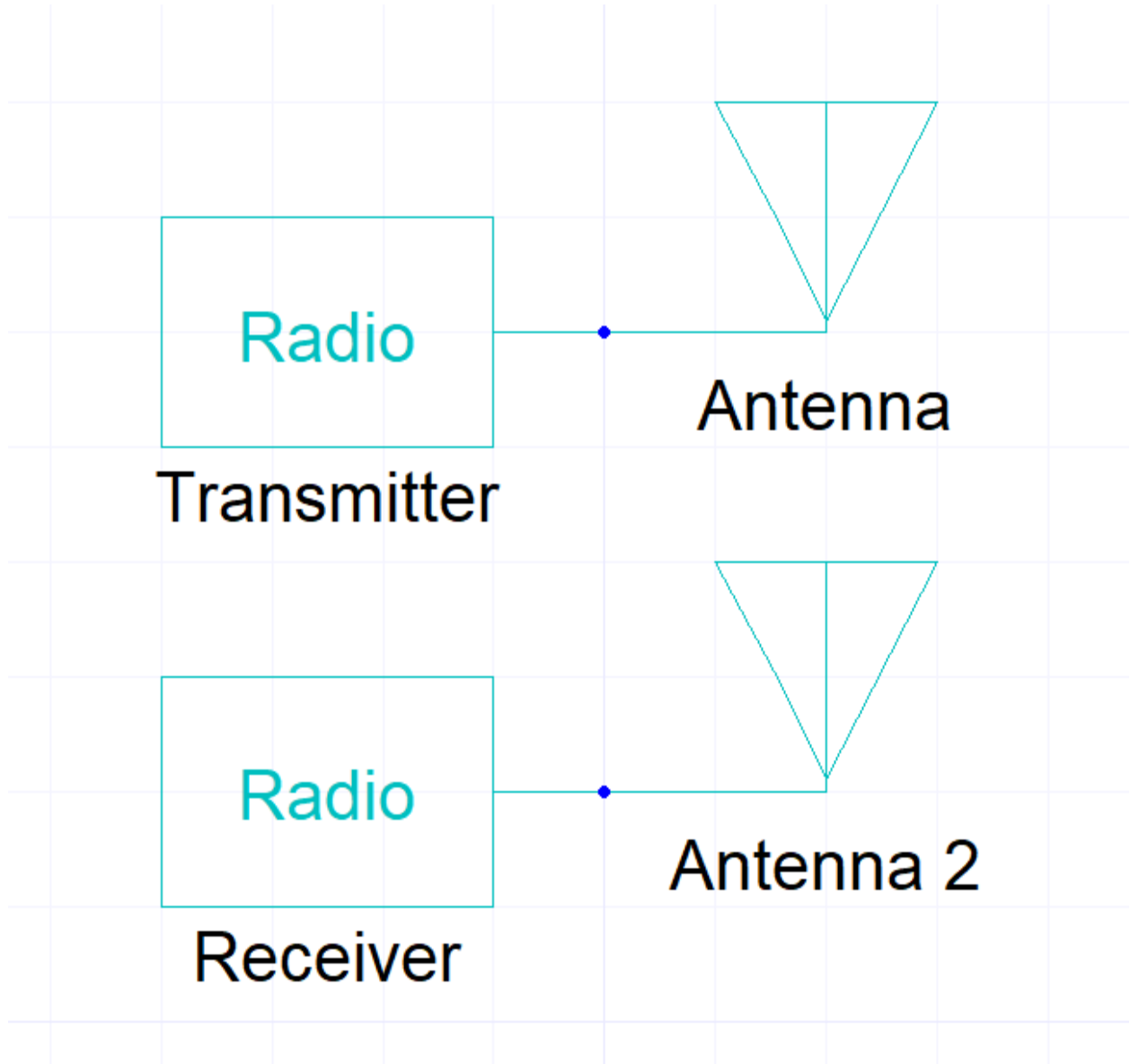

On the schematic, select the radio component by clicking on it, and then click again on the text below the component to edit it. Rename the component to *Transmitter*. Repeat the steps above to create a second radio component and rename it *Receiver*. After creating and renaming the two radios, click in any empty space on the schematic to deselect any selected components. Click on the Antenna icon () to add an antenna component to the schematic and automatically connect it to a radio. Do this again to create a second antenna for the second radio. The resulting schematic is shown below.



EMIT designs maintain a history of actions performed and you can undo and/or redo actions in the order that they were performed using the Undo  and Redo  buttons on the main Desktop toolbar.

3 - Define Radio Bands and Samplings

In EMIT, a radio's (Tx and Rx) capabilities are defined in the corresponding Configuration window, under the Radio node by specifying one or more Bands. Each Band has different operating characteristics defined by that Band node and its child nodes. Once a Radio's Bands have been defined, the actual operating conditions desired for the scenario are defined by the radio's Sampling. The Sampling node contains information related to the specific channels for which the radio will operate in the current scenario. The sampling parameters defined for a radio can also be used to simply reduce the number of channel combinations that EMIT needs to analyze as adjacent channels will often have similar cosite performance. The frequencies defined in a Sampling must be a subset of the Bands; i.e., the radio must be programmed only within its operational capabilities.

Band Definition

When radios are added to a project, a transmit/receive Band is automatically added to the radio. For this tutorial though, we want to make the bands transmit only and receive only for the Tx and Rx respectively. Double click the Transmitter radio to open the Transmitter Configuration window. To create a transmit only band, simply disable the Rx Spectral Profile node under the Band node. The Band icon should update to reflect that it is a transmit only band.

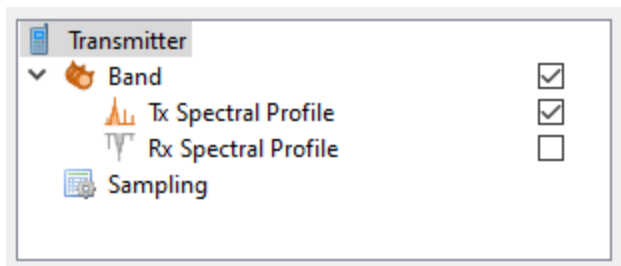

Next, we will configure the Tx's modulation and operating channels. Select the Band node to display its property panel and enter the values as shown below.

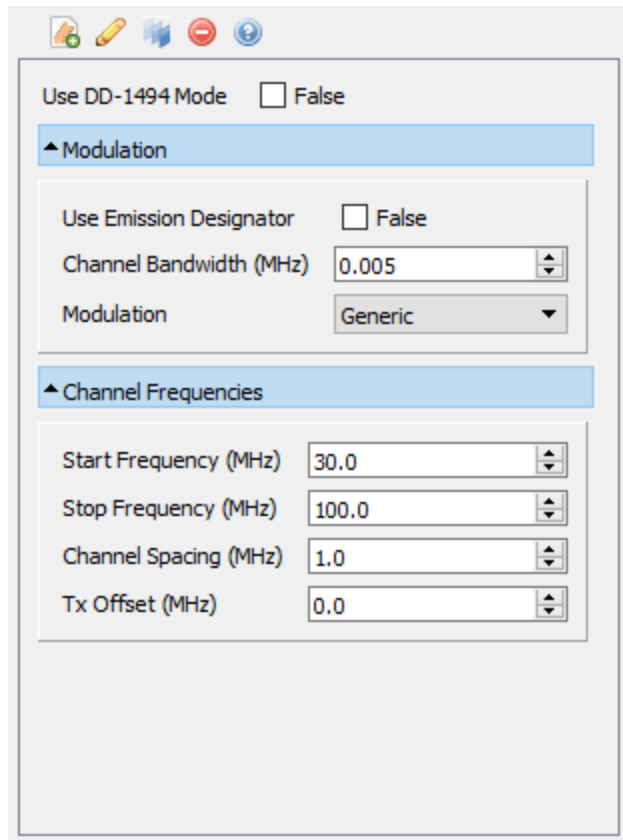

The Band node contains general properties that are required to define both transmit and receive parameters. To define the transmit specific parameters for this Tx band, select the Tx Spectral Profile node and enter the values as shown below. Detailed explanations for each parameter can be found in the appropriate sections of the EMIT help. Note that you can access the EMIT help by clicking the Help icon (🔗) to take you to the documentation for that specific node.

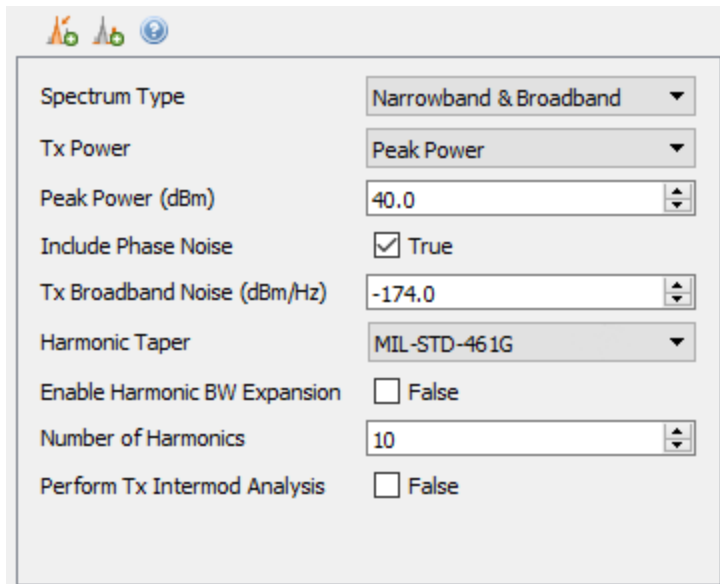

Spectrum Type	Narrowband & Broadband
Tx Power	Peak Power
Peak Power (dBm)	40.0
Include Phase Noise	<input checked="" type="checkbox"/> True
Tx Broadband Noise (dBm/Hz)	-174.0
Harmonic Taper	MIL-STD-461G
Enable Harmonic BW Expansion	<input type="checkbox"/> False
Number of Harmonics	10
Perform Tx Intermod Analysis	<input type="checkbox"/> False

In a similar fashion create a receive only band for the Rx, by opening the Receiver Configuration window, disabling the Tx Spectral Profile node, and then entering the parameters for the Rx Band and Rx Spectral Profile, respectively, as below.

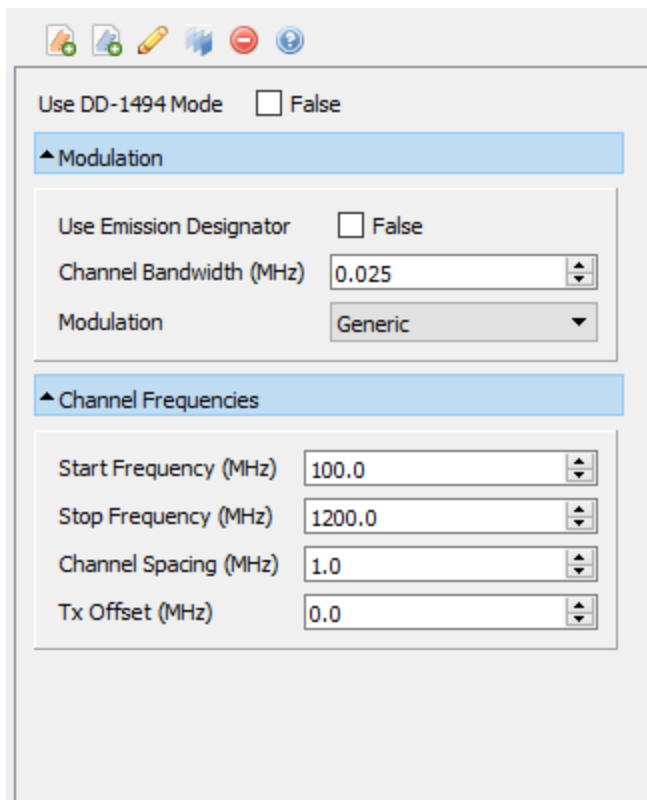

Use DD-1494 Mode	<input type="checkbox"/> False
▲ Modulation	
Use Emission Designator	<input type="checkbox"/> False
Channel Bandwidth (MHz)	0.025
Modulation	Generic
▲ Channel Frequencies	
Start Frequency (MHz)	100.0
Stop Frequency (MHz)	1200.0
Channel Spacing (MHz)	1.0
Tx Offset (MHz)	0.0

In this instance we also know the IF that the receiver uses to downconvert the desired signals as well as the specifications for the IF filters. Thus, we want to include this information in our cosite analysis to increase the fidelity of the simulations. To do so add Mixer Product and Selectivity Profile nodes to our Rx Spectral Profile. Right-click on the Rx Spectral Profile and select Add Mixer Products and then repeat to Add Rx Selectivity. Edit the parameters of each of these, as shown below.

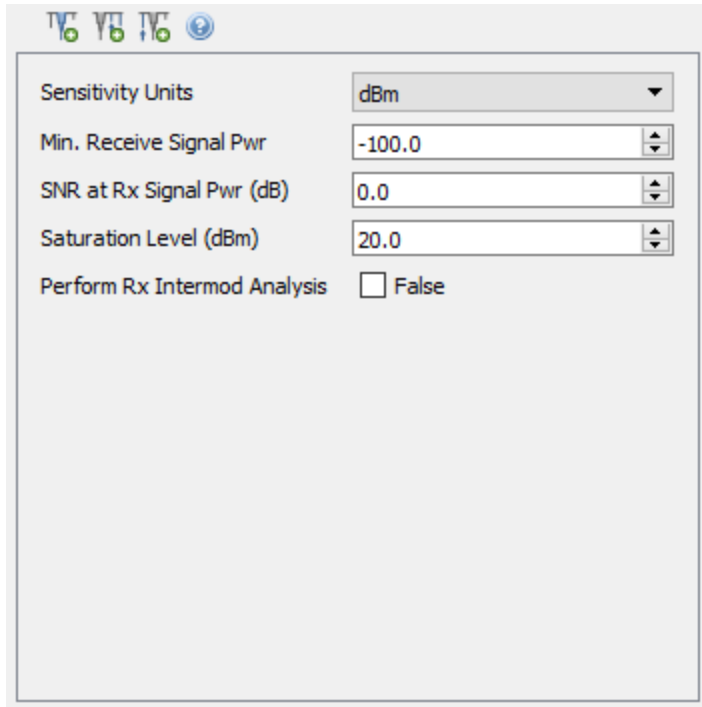

The selectivity profile defines the shape of the Rx's response at the tuned channel which is determined by its IF filters.

Mixer Product Taper: Duff Model

Mixer Product Slope (dB/decade): 35.0

Mixer Product Intercept (dBc): 75.0

Maximum RF Harmonic Order: 2

Maximum LO Harmonic Order: 2

Mixing Mode: LO Below Tuned (RF) Frequency

1st IF Frequency (MHz): 55

Mixer Product Table Units: Absolute

RF Harmonic Order	LO Harmonic Order	Power (dBm)
-------------------	-------------------	-------------

Add Row Remove Selected Rows

Selectivity

Bandwidth (MHz)	Attenuation (dB)
0.050000000	60.000000000
0.100000000	120.000000000

Add Row Remove Selected Rows

Take some time to further explore the help sections for the Band settings, and the Tx and Rx spectral profiles. The parameters specified in these nodes define the broadband characteristics of the transmitter and receiver, respectively. For transceivers that use the same modulation for transmitting and receiving as well as identical channels (or a fixed offset) a single Band can be defined with the spectral profiles defining the Tx and Rx specific parameters.

Sampling Definition

The Bands define the complete operational capabilities of a radio. Typically though, in a given scenario, a radio will only operate over a subset of its abilities. In EMIT, a radio is programmed for a scenario using the radio's Sampling node to specify the channels that the radio will actually operate on within the scenario. For example, a radio may be capable of operating on 100 channels (which is defined by the radio's Band), but for the scenario of interest, operation is restricted to just 5 of these channels.

By default, a Sampling is added to the radio when it is created. After opening the Transmitter Configuration window, select the Sampling node for the transmitter and enter the properties as shown below. Note that we are only defining a single 50 MHz channel that the Tx will operate on for this scenario. It is worth noting that the Total Tx Channels field shows the number of channels that the Sampling has in common with all of the Bands defined for that Radio.

The screenshot shows the Sampling configuration window with the following parameters:

- Sampling Type: Uniform Sampling
- Specify Percentage: False
- Max # Channels/Range/Band: 1000
- Total Tx Channels: 1
- Total Rx Channels: 0

The Frequency Ranges table is as follows:

Min (MHz)	Max (MHz)
50	50

Buttons: Insert Row, Remove Selected Rows

In a similar fashion, select the Sampling for the Receiver and enter the parameters as below.

The screenshot shows a software configuration window with the following elements:

- Sampling Type:** A dropdown menu set to "Uniform Sampling".
- Specify Percentage:** A checkbox labeled "False" which is currently unchecked.
- Max # Channels/Range/Band:** A numeric input field containing the value "1000".
- Total Tx Channels:** A numeric input field containing the value "0".
- Total Rx Channels:** A numeric input field containing the value "1".
- Frequency Ranges:** A section with a dropdown arrow and a table below it.

Min (MHz)	Max (MHz)
500	500

At the bottom of the "Frequency Ranges" section, there are two buttons: "Insert Row" and "Remove Selected Rows".

4 - Modify Radio Channels

Before proceeding with an exploration of ways radio channels can be modified, rename both radios. This will facilitate adding more radios to this project in a later tutorial. Click on the Transmitter radio to select it, then click the text below to edit its name and type in Tx-1 (Lo-VHF). Change the name of the Receiver radio to Rx-0 (UHF). The schematic should now appear as below.

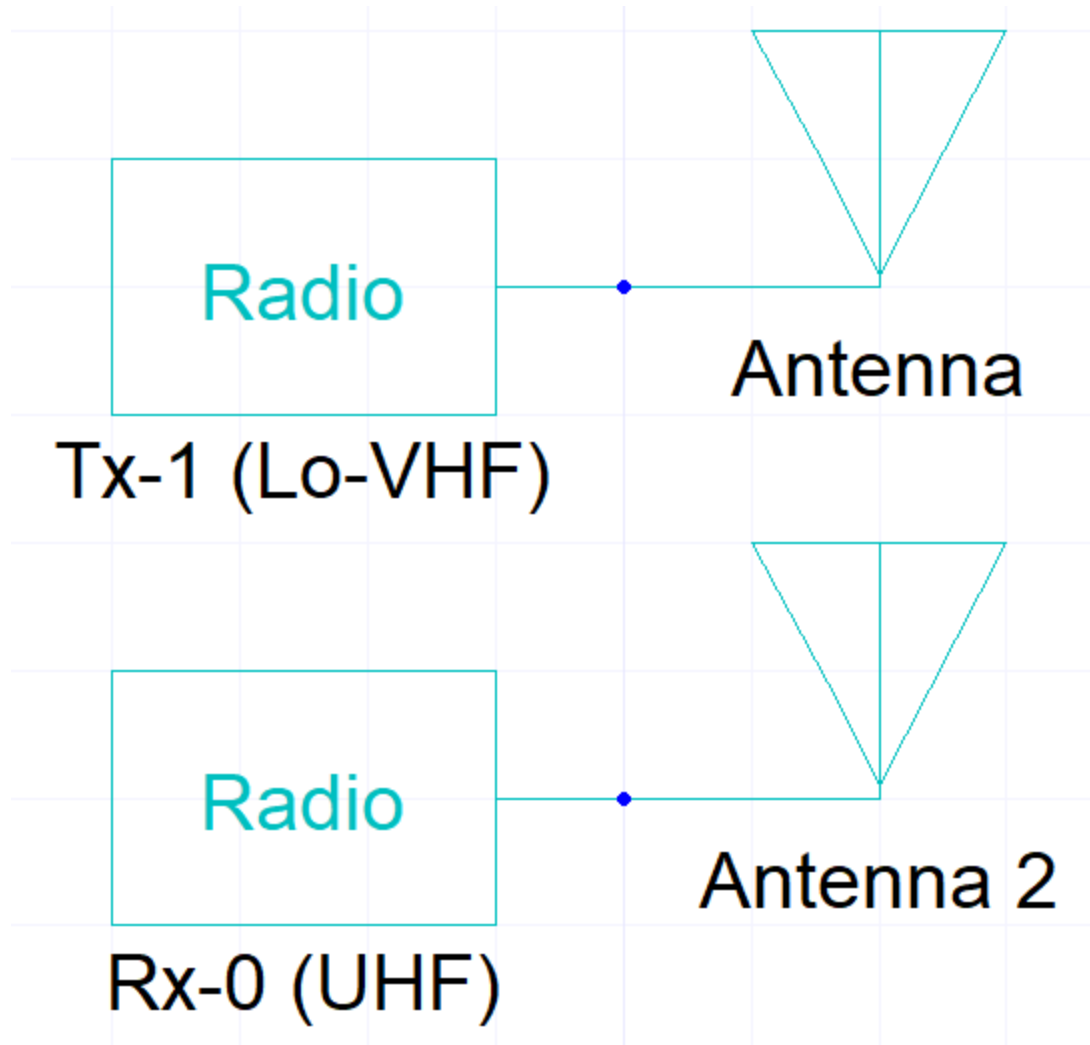

Now we will explore the additional features that can be added to the already defined Tx and Rx channels in EMIT. These features include adding Tx and Rx spurious responses (spurs), changing the transmitter harmonic levels, and changing the Rx mixer product levels.

First, plot the Tx emissions spectral profile by double-clicking the Tx-1 (Lo-VHF) radio and selecting the Tx Spectral Profile node. A plot of the wideband Tx emissions will appear in the display area on the right side of the window. The first channel of the Band, 30 MHz in this case, is displayed by default, but the plot can be changed to show any channel in the Band. By clicking Band 30 MHz (Tx) Trace in the legend of the plot, the trace's properties will be displayed. Set the Channel Frequency to 50 MHz, which is the operating channel we will use for this simulation. By clicking the Plot Properties icon (🔗) above the plot, the plot properties will be displayed. Verify that the X-axis Max value is set to 600 MHz. The resulting plot is shown below.

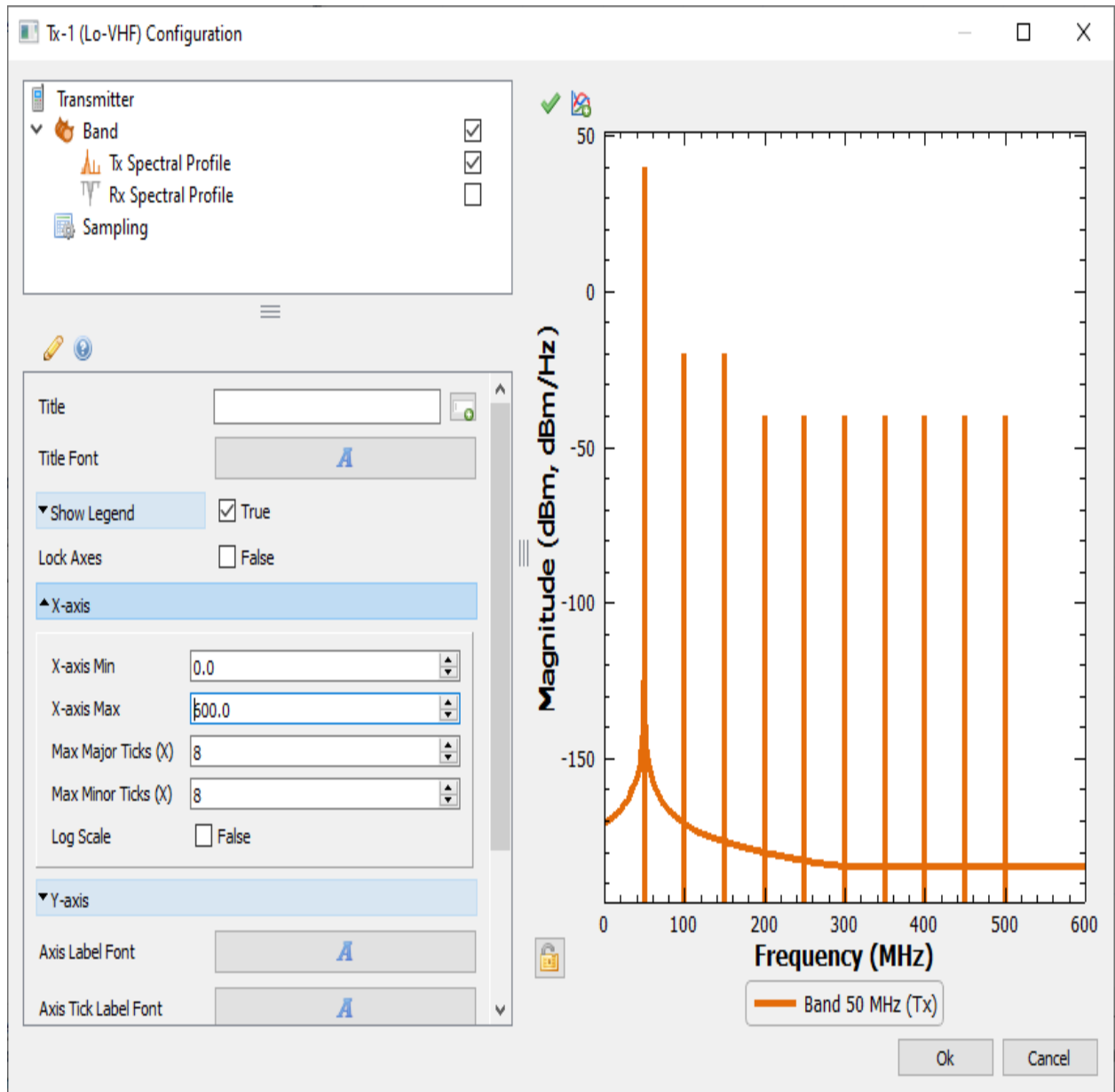

The Tx Spectral Profile has two components:

- The narrowband component is in units of power. For our Tx, this component consists of the Tx fundamental at the channel frequency of 50 MHz and a number of harmonics (the number of harmonics included are specified in the Tx Spectral Profile definition). The amplitude of the harmonics in this case are set to the MIL-STD-461 limits.
- The broadband, or noise, spectral component is in units of power density (power/unit bandwidth). We are currently using the default value of the unit bandwidth (1.0 Hz). Therefore, our broadband noise units are dBm/Hz. For our Tx the noise floor has been specified as being -174 dBm/Hz and we have enabled the option to compute the phase noise about the channel frequency.

Clicking on a trace within the legend in the plot highlights that trace on the plot by increasing the width of the trace. Plots have quite a bit of functionality built in for customizing the display. Refer to the EMIT help for a detailed explanation of plot functionality by clicking on the Help icon ().

Based on the parameters specified in the Tx Band and Spectral Profile definitions, this is the best model for the Tx emissions using the spec-sheet type data provided. However, EMIT allows this spectral profile to be modified and refined as more data on the Tx performance becomes available beyond the simple spec-sheet type information. For example, harmonic levels can be adjusted to represent the actual levels and non-harmonic spurious emissions can also be added. If Tx emissions data is available from another source (for example, measurements, RF circuit simulations, and so on) this can be used in EMIT as well by importing the data into the appropriate node.

To adjust the level of a specific harmonic, right-click on the Tx Spectral Profile node and choose **Add Custom Tx Harmonics**. A Harmonics node will appear under the Tx Spectral Profile node. In the Harmonics property panel, add a row to the table to adjust the amplitude of the desired harmonic(s) (note that the fundamental is harmonic number 1, the first harmonic is harmonic number 2, etc.). For this tutorial, we'd like to set the amplitude of the 2nd harmonic to -75 dBm as shown below. Note that the plot of the harmonics will automatically update after making the changes. Any number of harmonics can be modified using this table and external CSV files containing the harmonic numbers and their amplitudes can also be imported via the import icon ().

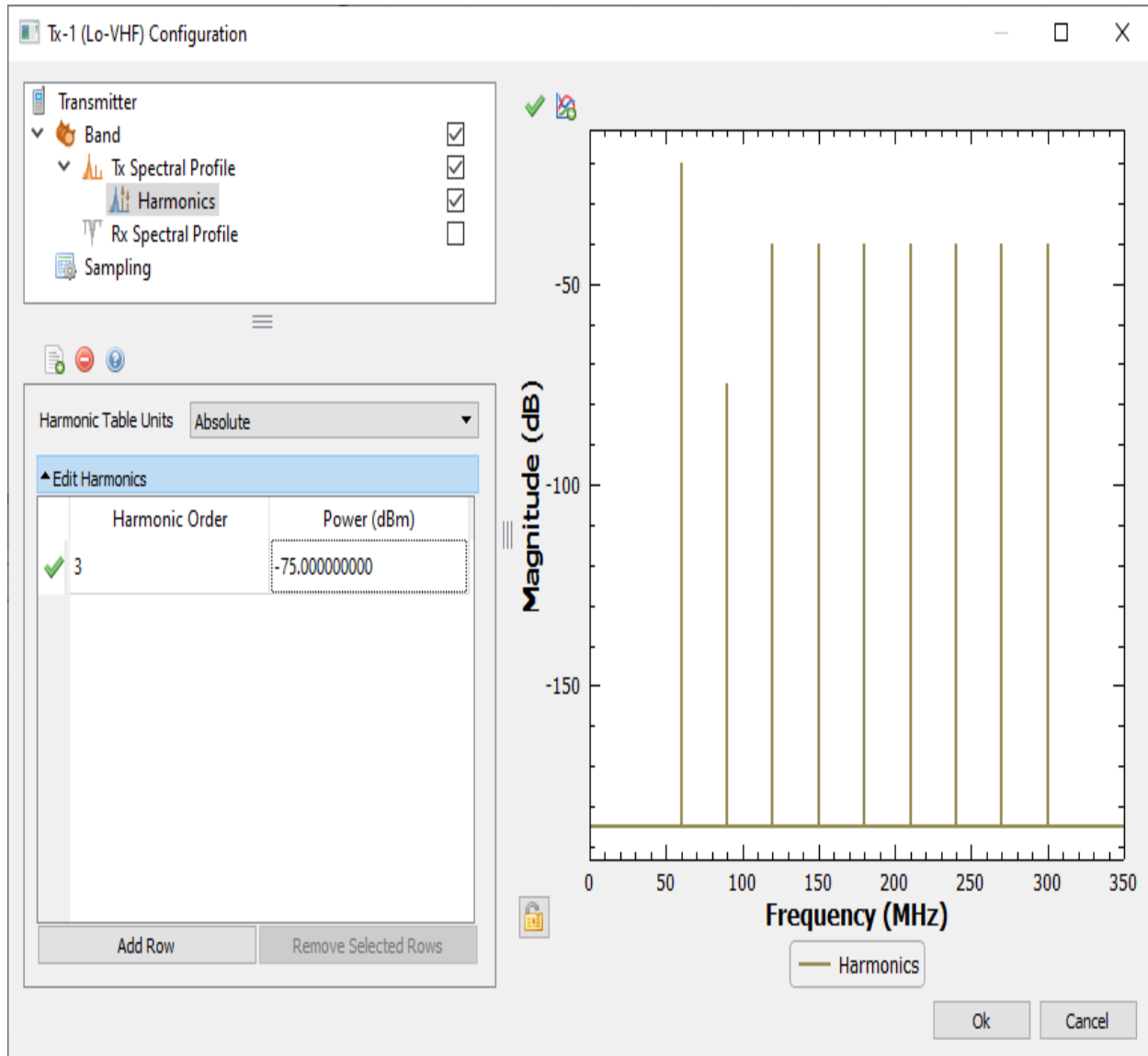

To add a non-harmonic spur, right-click on the Tx Spectral Profile node and select Add Spurious Emissions. A Spurious Emissions node will appear under the Tx Spectral Profile. Spurs can be defined as either fixed or relative. Fixed spurs remain at the specified frequency regardless of the channel frequency, while relative spurs appear at a specified offset from the channel frequency for each channel defined in the Band. In the Spur property panel, add a row to the table and enter "RF+10" in the Frequency column. The RF variable specifies that it is a relative spur, and that the frequency of the spur will be set to 10 MHz above the tuned channel. Define the spur's bandwidth and amplitude as shown below. As before, the plot will automatically update after the changes are made. Any number of spurs can be added via this table and external CSV files containing the spurs' frequency, bandwidth and amplitude can also be imported via the import icon ().

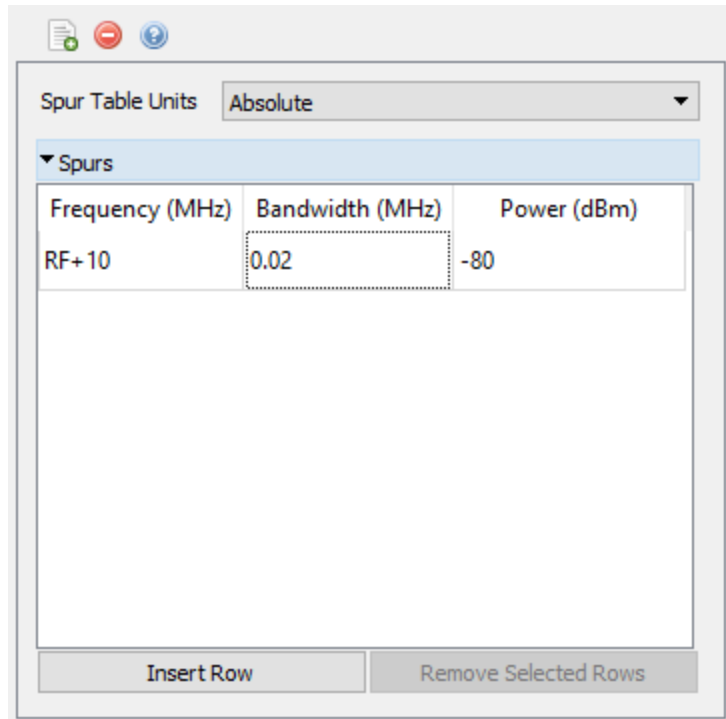

Similarly, we can modify the Rx Spectral Profile by editing mixer product responses and adding non-mixer product spurious responses. Plot the Rx Spectral Profile by selecting the Rx Spectral Profile node in the Rx-0 (UHF) Configuration window. A plot of the wideband Rx susceptibility will appear in the display area. In the Trace node's property panel, which is accessed by selecting Band 100 MHz (Rx) in the legend of the plot, set the Channel Frequency to 500 MHz to display the corresponding channel for the Rx band.

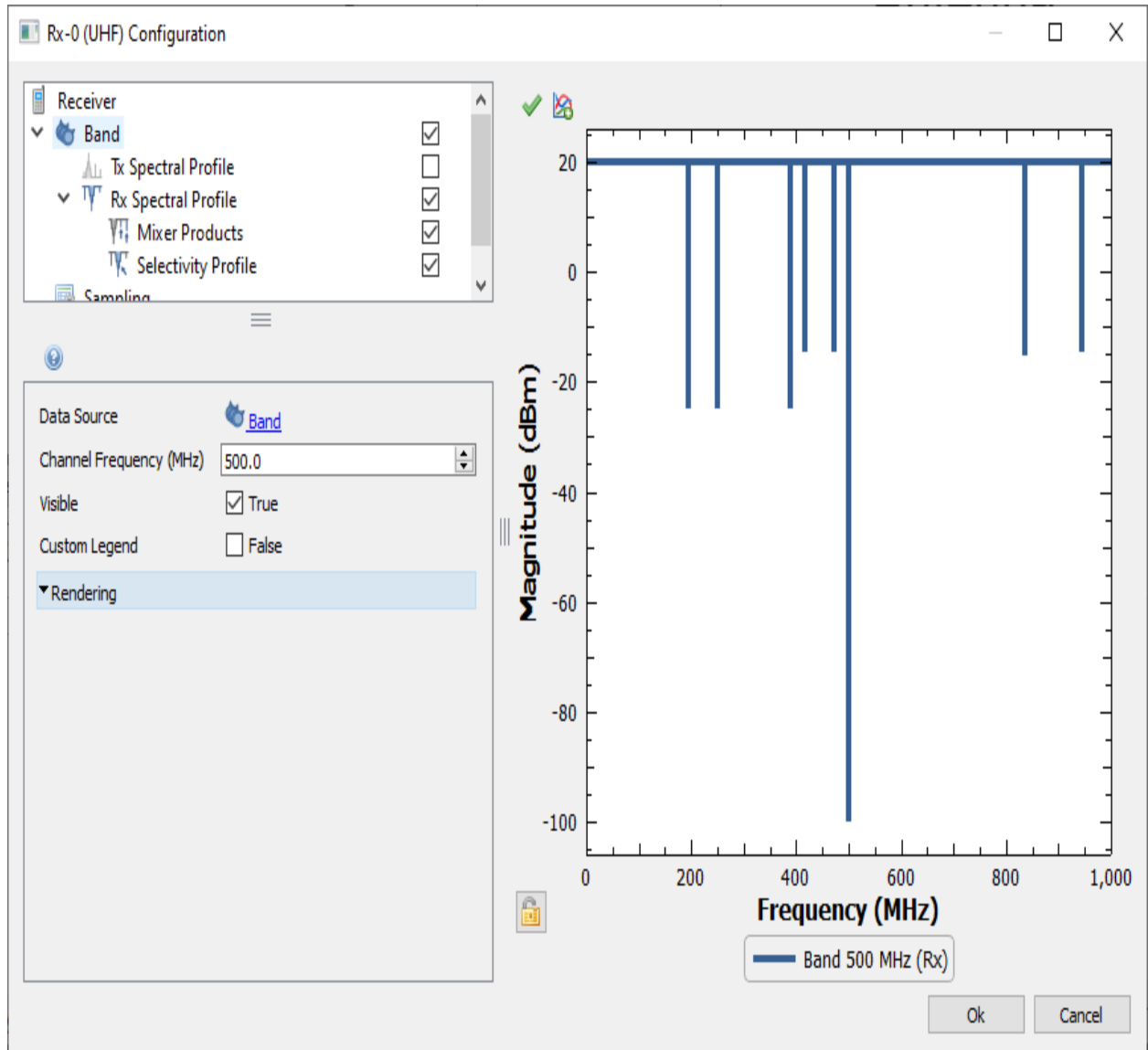

The wideband Rx susceptibility for this 500 MHz channel shows an in-channel susceptibility of -100 dBm, a saturation level of +20 dBm and multiple mixer products as previously specified in the Rx Band's Mixer Product node. Recall that the mixer product levels in this case are defined by the statistical Duff Model.

Use the left mouse button in the Rx plot window to "rubber-band" zoom in to view the susceptibility response around 500 MHz. The shape of the susceptibility curve in this region is defined according to the Selectivity Profile child node of the Rx Spectral Profile. You can also control the exact axis extents from the plot property panel, opened by clicking the Plot Properties icon (🔍).

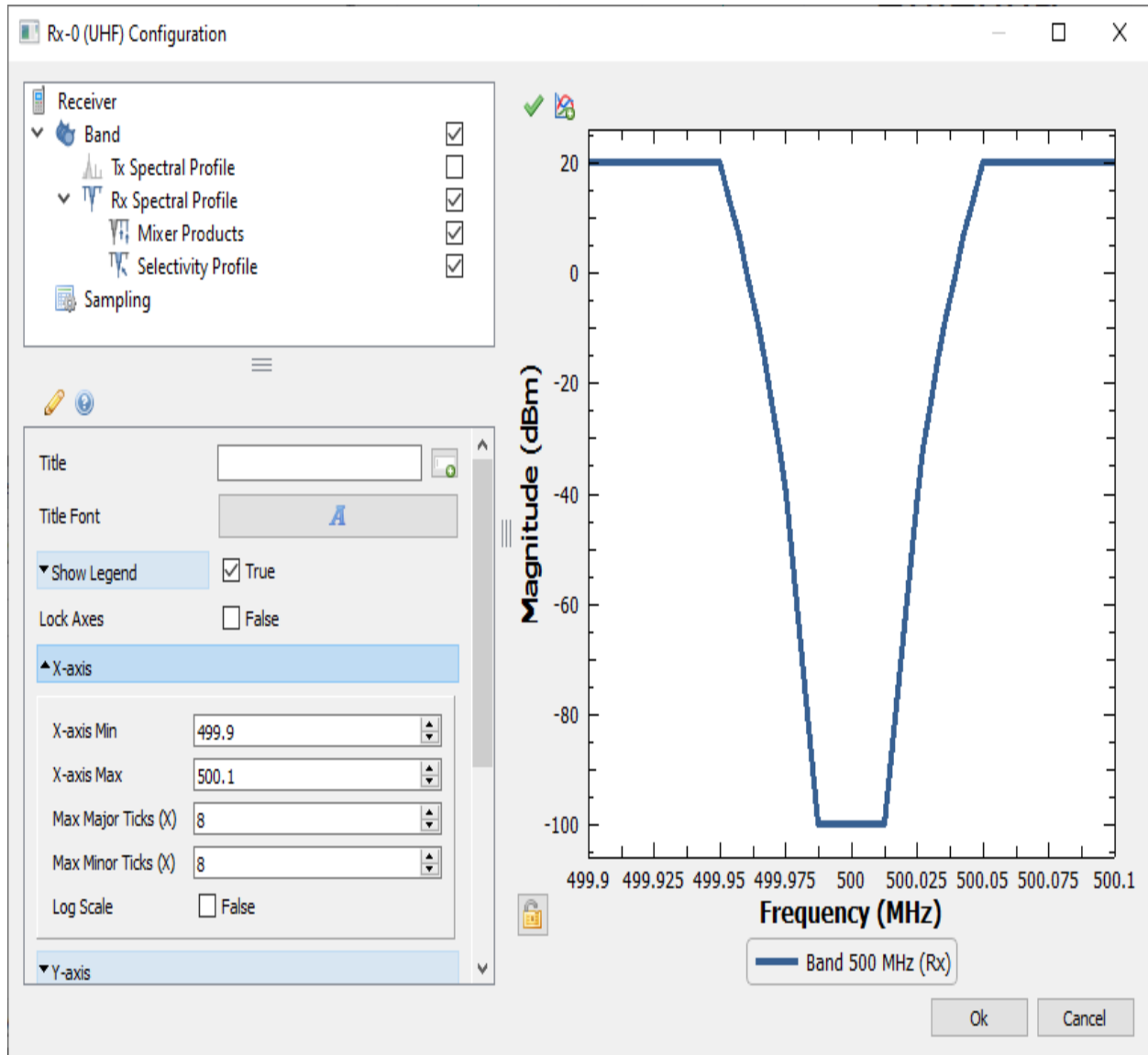

Double-click in the Rx plot area to reset the zoom for the Rx susceptibility plot. The susceptibility spectral profile can also be modified as higher fidelity data becomes available as was done for the Tx emissions spectral profile above. For the Rx, we can adjust mixer product levels and add other spurious responses.

Select the **Mixer Products** node which was previously added for the Rx. In the Mixer Products property panel, add a row to the table and set the parameters as shown below. Observe the change in the susceptibility plot.

Rx-0 (UHF) Configuration

Receiver

- Band
- Tx Spectral Profile
- Rx Spectral Profile
 - Mixer Products
 - Selectivity Profile
- Sampling

Mixer Product Taper: Duff Model

Mixer Product Slope (dB/decade): 35.0

Mixer Product Intercept (dBc): 75.0

Maximum RF Harmonic Order: 2

Maximum LO Harmonic Order: 2

Mixing Mode: LO Below Tuned (RF) Frequency

1st IF Frequency (MHz): 55

Mixer Product Table Units: Absolute

▲ Edit Mixer Products

	RF Harmonic Order	LO Harmonic Order	Power (dBm)
<input checked="" type="checkbox"/>	1	2	10.000000000

Add Row Remove Selected Rows

Magnitude (dB)

Frequency (MHz)

— Mixer Products

Ok Cancel

Next, we want to add a spurious response to our Rx Spectral Profile. Right-click on the Rx Spectral Profile node and select **Add Spurious Responses**. In the table, add a row and set the columns as shown below. Note that the value entered for the Frequency column does not contain any variables and is thus a fixed spur, which means that it will appear at 600 MHz for every channel defined in the Band.

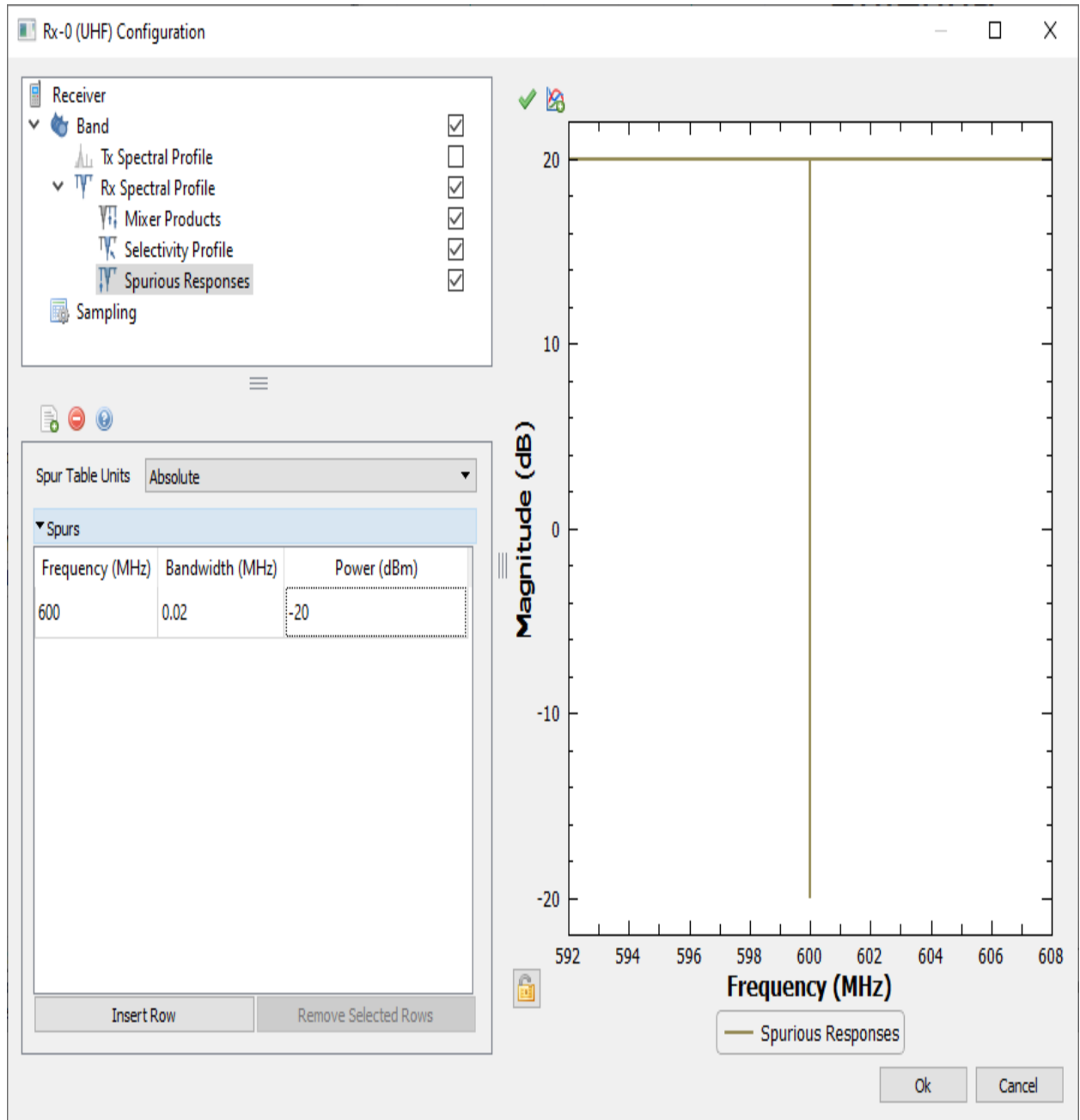

This completes the definition of the Tx and Rx radios for this tutorial.

5 - Antenna Coupling

In general, the coupling between antennas is required for computing cosite EMI. This requires defining antennas in EMIT and specifying their coupling. EMIT offers several different models for antenna coupling and these will be covered in detail in later tutorials. In this tutorial, antennas were added but they were defined as Positionless. This means that EMIT's Global Default Coupling will be used and for this tutorial we want to set the Global Default Coupling to -40 dB. To set this level, first open the Coupling Editor by either double-clicking either antenna or selecting the Coupling Editor in the Simulation tab in the ribbon area, shown below.

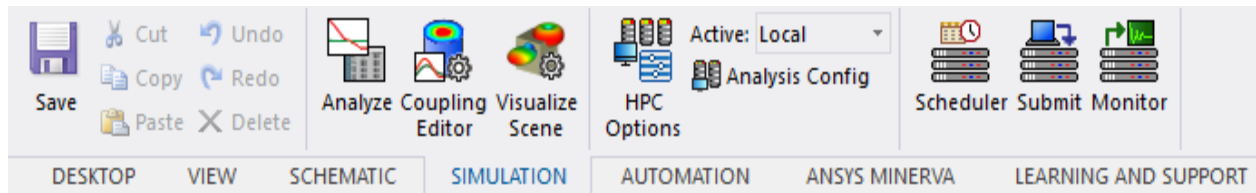

Select the **Coupling Data** node in the node tree and set the Global Default Coupling value as shown below. Click **OK** to save the changes.

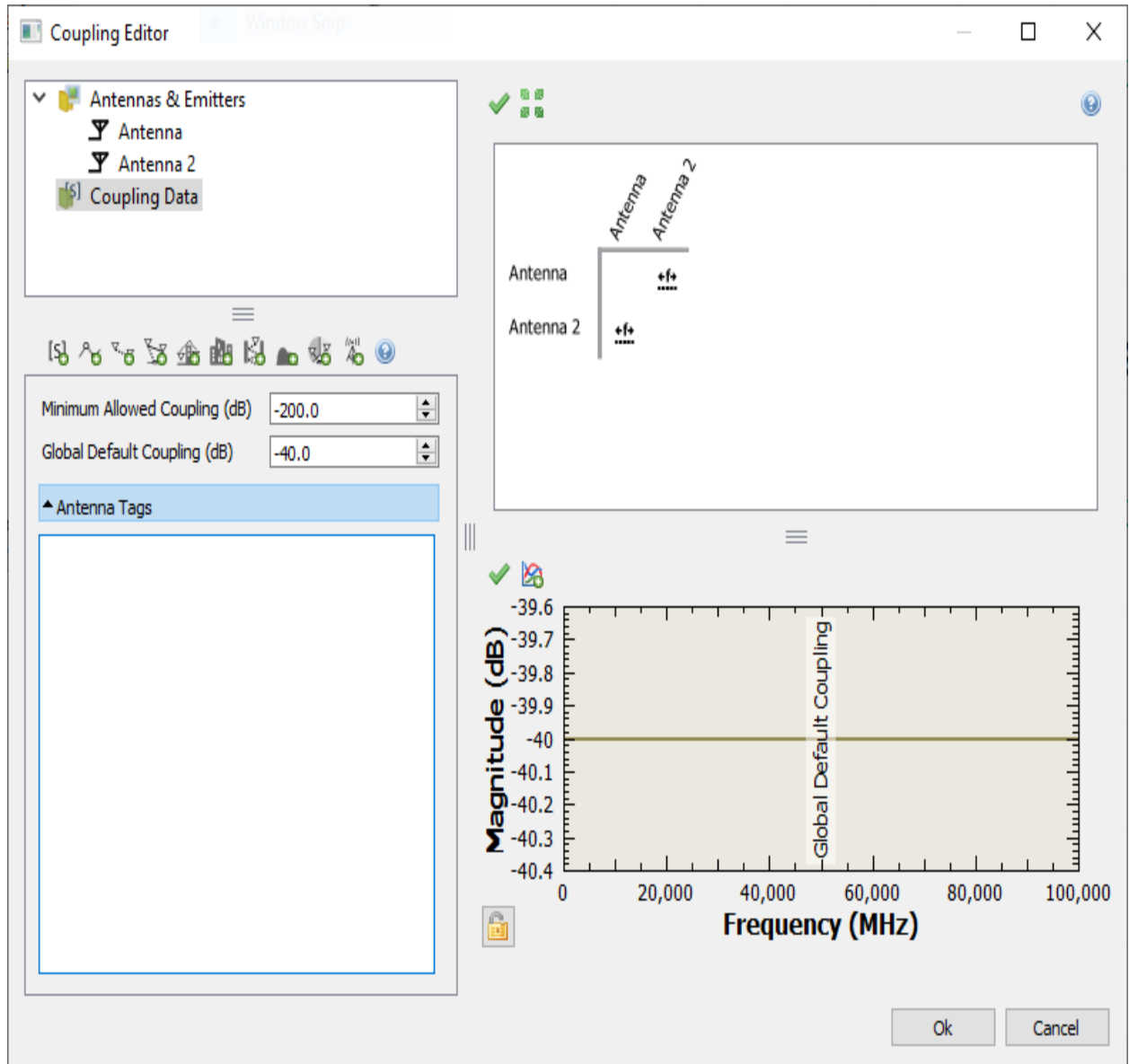

6 - Run the Simulation

At this point, we have a valid EMIT scenario that is ready to simulate. First, select **Analyze** on the **Simulation** tab.

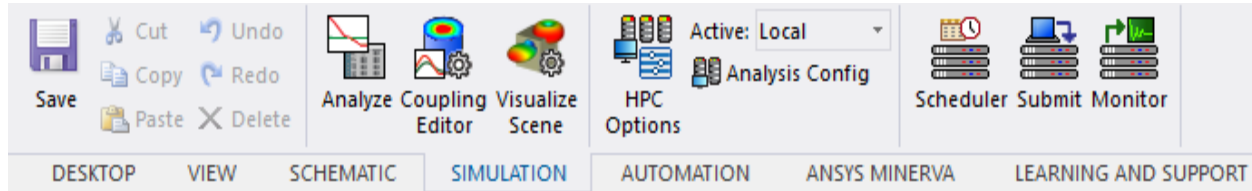

This opens the analysis window and you can learn more about all of the sub-windows it is comprised of by clicking the Help icon (📘). The Scenario Matrix is found in the top left corner, and in this simple tutorial there is only one Tx/Rx pair for the simulation, and only a single Tx/Rx pair shown in the matrix. The [N to 1] column shows the worst-case interference for the Receiver caused by any combination of Transmitters. In this scenario, it is disabled because there is only a single transmitter, Tx-1 (Lo-VHF), that can interfere with the Rx-0 (UHF) receiver. For more information on EMIT's N-to-1 analysis capabilities, see Tutorial 3.

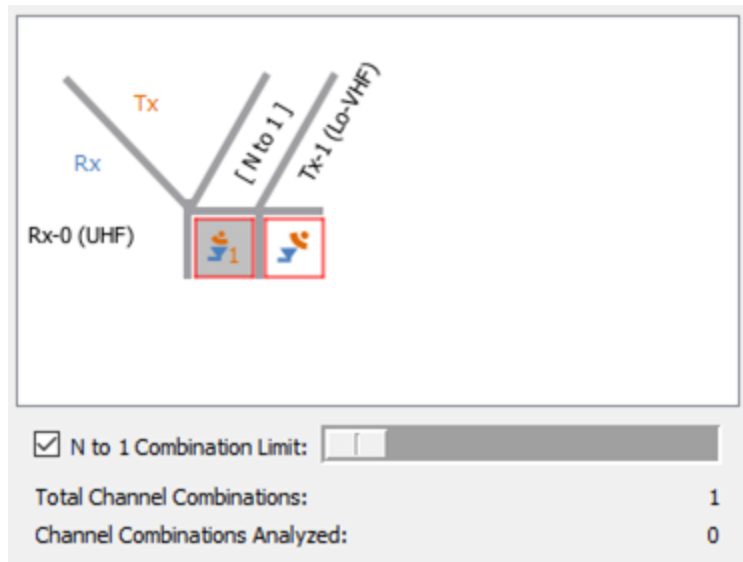

There are several ways to launch a simulation in EMIT. Here we will run the analysis by selecting the Run icon (▶) above the Scenario Matrix. One can also perform the simulation from the Scenario Matrix by right-clicking on the matrix square for a particular Tx/Rx pair and selecting Run, or simply by double-clicking on any matrix square. The result is automatically stored in the design's Results folder in the Project Manager window, and the analysis window can be re-opened later.

Once the simulation is run, the entries in the Scenario Matrix will update with a color to reflect the results of the analysis. By default, red indicates a positive EMI margin; i.e., the presence of interference. Green indicates no interference, and yellow indicates no interference by only a small margin. These colors can be configured by selecting the By EMI Margin tab at the top-right of the window. In this case we will use the default values.

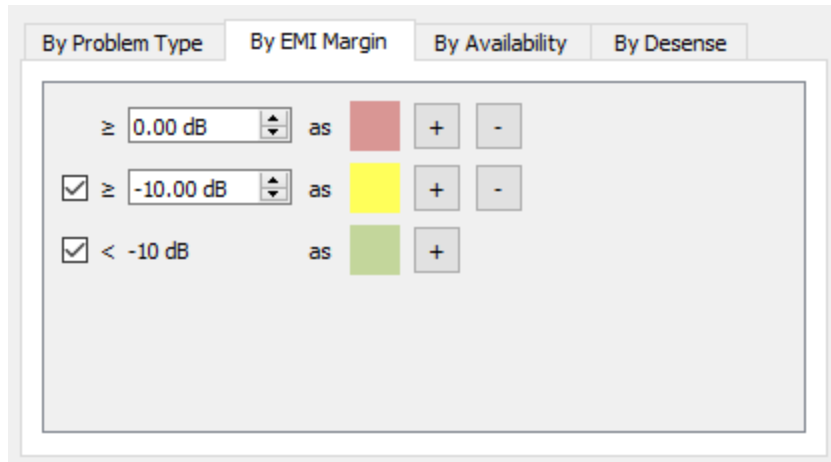

If you haven't done so, run the simulation using one of the aforementioned methods. The bottom of the Scenario Matrix provides some summary statistics on the run. It displays the Total Channel Combinations defined in the scenario as well as the Channel Combinations Analyzed. At this point in this simple tutorial, both of these values should be 1, however, as we will see in later tutorials, it is possible to run a subset of the total scenario.

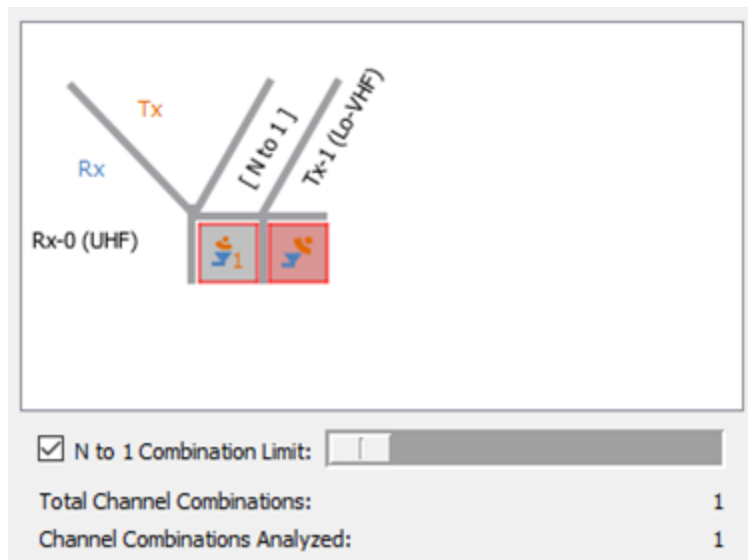

Below the Scenario Matrix, the Scenario Details immediately shows us that there is an interference problem with a +20 dB EMI margin. The Scenario Details allows us to navigate through the Radios defined within our project to quickly analyze the results. The left side of the Scenario Details lists all of the transmitters in the project and the right side all of the receivers.

Transmitters		EMI
▼	All	● 20.0
▼	Tx-1 (Lo-VHF)	● 20.0
>	Band	● 20.0

Receivers		EMI
▼	All	● 20.0
▼	Rx-0 (UHF)	● 20.0
>	Band	● 20.0

As different nodes in the Scenario Details are selected, the Interaction Diagram and Result Plot (shown below) will automatically update to show the results for that node, though in this case all the results are the same since there is only a single channel combination to analyze.

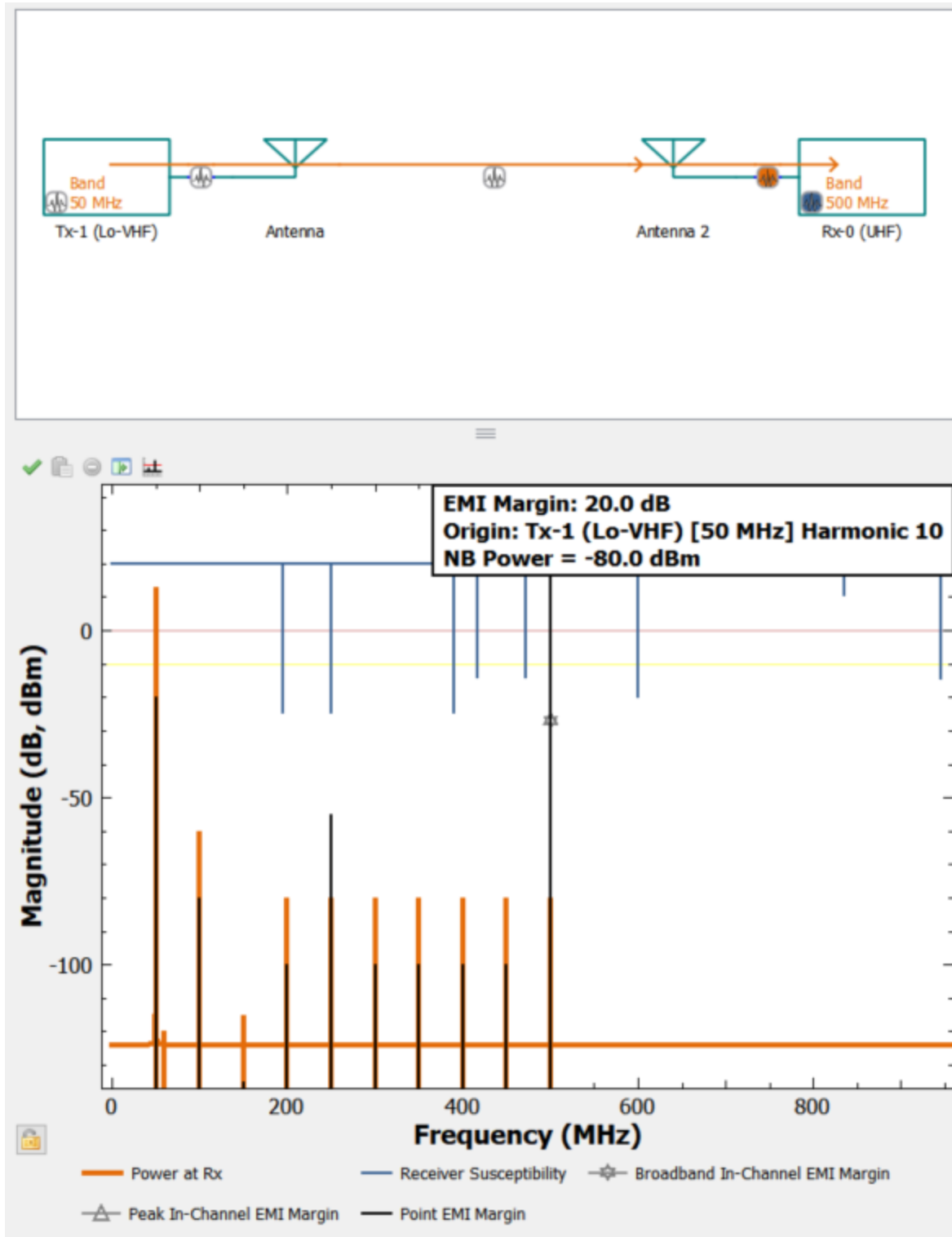

In general, a node in the Scenario Details will display the worst-case result for all its sub-nodes. The one exception is the individual channel nodes which do not have any sub-nodes and thus show the result for that channel itself. Select the Band nodes in the Scenario Details to expand

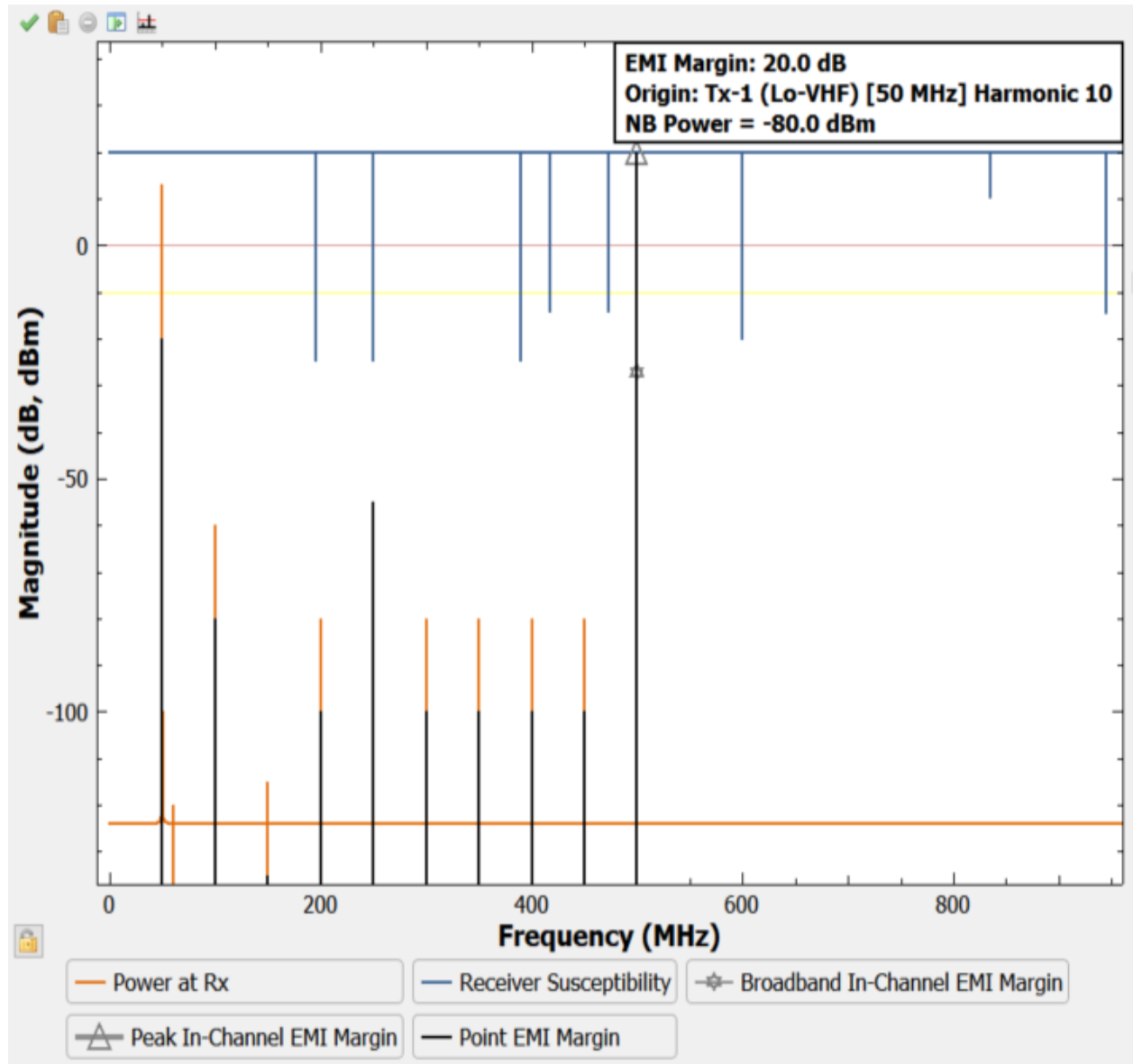

them to show all available channels (as defined by the Samplings) and then select the 50 MHz and 500 MHz channels, respectively. Normally this would refresh the Result Plot to show the detailed results for this channel combination, but since it's the only possible combination, its result was already displayed.

Let's now look at the Result Plot in more detail to better understand the cause of the interference in our Rx.



As a quick aside, here is an overview of the data displayed in the Result Plot:

- Power at Rx (orange) - this is the power level directly at the input to the receiver. For this simple 1-1 case, the Power at Rx is the Tx's Spectral Profile plus the antenna-to-antenna coupling.

- Rx Spectral Profile (blue) - defined by the Rx Band, Rx Spectral Profile, and any child nodes (i.e. Mixer Products, Selectivity Profile, Spurious Responses).
- Point EMI Margin (black) - defines the EMI margin for each narrowband spectral component.
- Broadband in-channel EMI margin (). The EMI margin in the tuned Receiver's channel bandwidth due to broadband noise.
- Peak in-channel EMI margin () - The EMI margin in the tuned Receiver's channel bandwidth due to narrowband components that fall within the channel bandwidth.
- EMI Thresholds (red and yellow) - horizontal traces showing the thresholds set in the Result Categorization window.
- Plot marker and label () - highlights and provides additional information regarding the largest cause of interference.

By analyzing the Result Plot we see that there is only one frequency where a positive EMI margin occurs and that is at the Rx tuned channel frequency of 500 MHz, making it an in-channel interference problem. It is easily seen that all other EMI margins (that is, Point EMI and Broadband in-channel EMI) are below both the yellow and red thresholds that we defined. The plot marker and label also tell us that this in-channel interference is due to the 10th harmonic of our transmitter which falls directly on the Rx channel at 500 MHz. Since the harmonic is an unintended emission from our transmitter, this interference can be easily mitigated by adding a low pass filter to the output of our transmitter which will attenuate the harmonics.

7 - Add a Filter for Interference Mitigation

A simple low pass filter will allow the transmitter's fundamental to pass with little impact but will attenuate the harmonics sufficiently to eliminate the interference. To add a filter to the Tx, click on the Filter icon () in the ribbon area and select Low Pass (the type of filter can be modified later). Insert the Filter between the Tx and its antenna by moving the antenna to the right by left-clicking and dragging it over with the mouse, then right-clicking on the wire connecting the radio and the antenna and selecting Delete. Make sure the space between the ports of the radio and the antenna is wide enough to fit the filter, then move the Filter in between the Tx and antenna and connect the three components as seen below by either left-clicking on one port and dragging the connection to the next port, or by selecting the Filter and using the Reposition button found in the ribbon area in the Schematic tab. The Reposition button will automatically move and connect the component to a valid port. If there are multiple valid connections, then you can cycle through them by clicking the Reposition button multiple times. Similarly, clicking the Reorient button will cycle the selected component through all possible orientations. Note that some 2-port components, most notably Cables and Filters, are orientation agnostic.

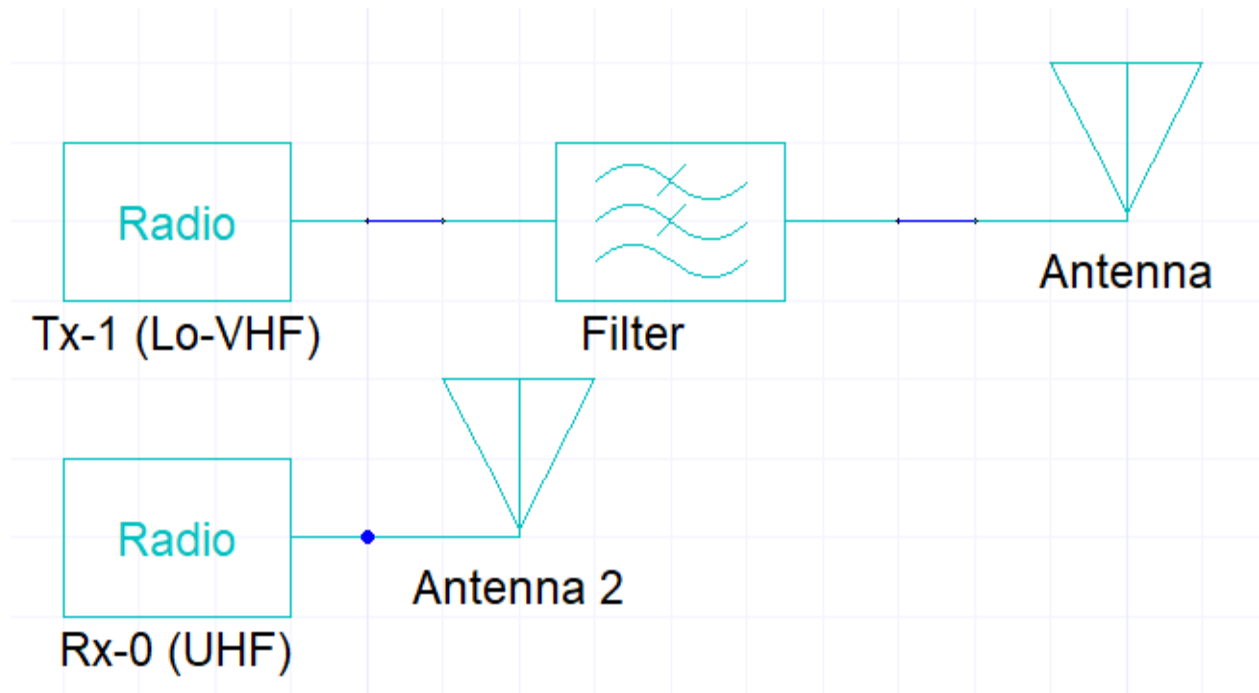

Double-click on the Filter to open the Filter Configuration window and set the Filter's properties as shown below to automatically plot the filter's response.

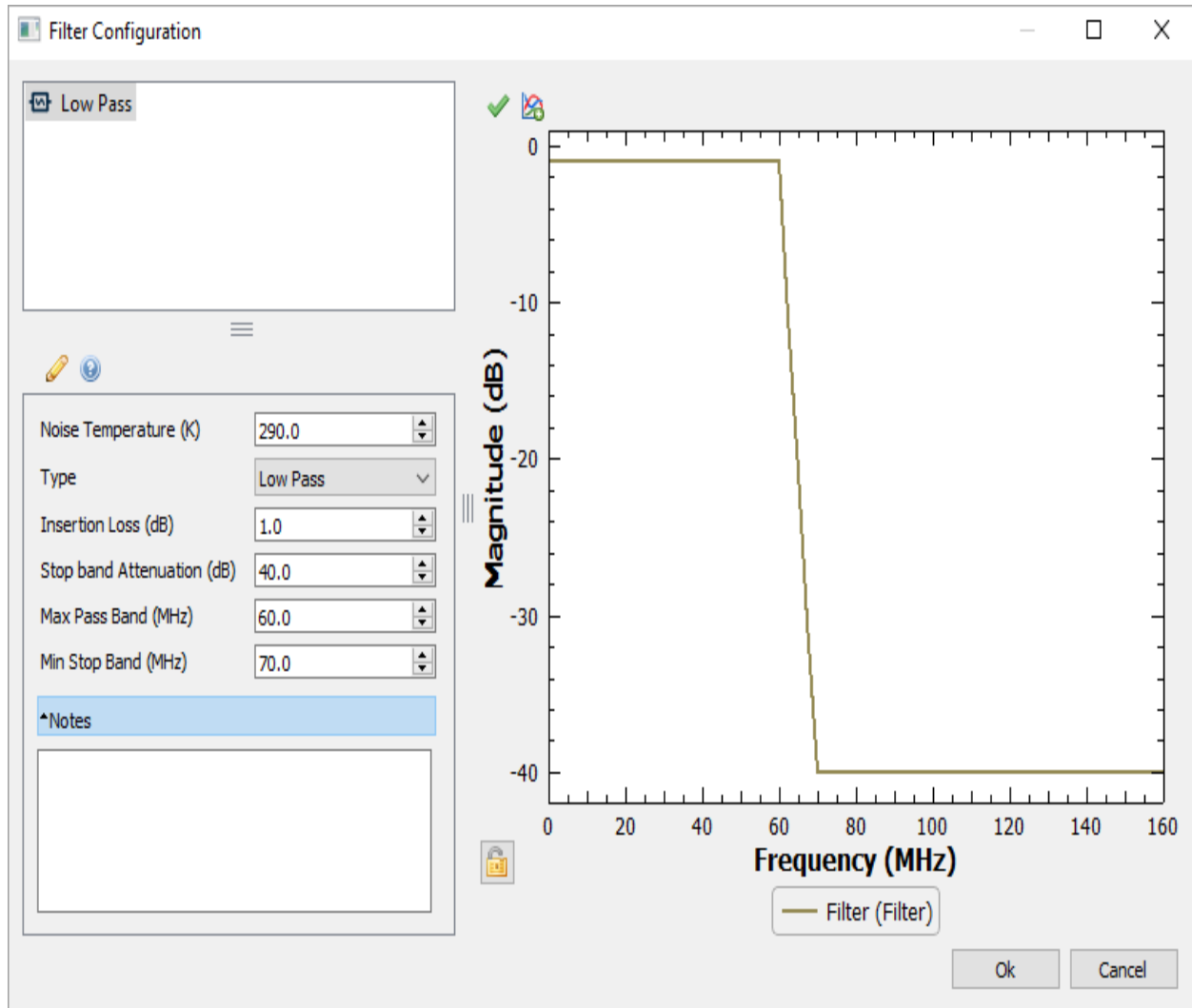

You may have noticed the previously obtained results have been crossed out in the Project Manager window. The result has been crossed out because it is no longer valid for the design due to the addition of the filter. Rename the crossed-out result by right-clicking and selecting rename, changing the name to *Result 1 – No filter* as shown below. This enables us to review past results even after running new analyses for modified designs, in order to compare the effects of our modifications.

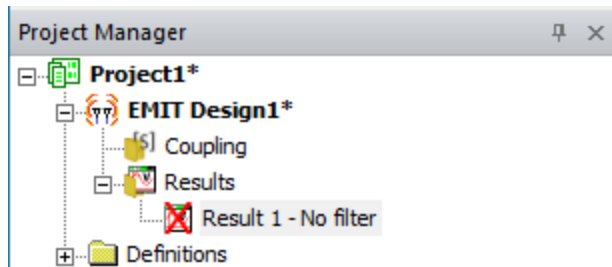

Click **Analyze** under the Simulation ribbon tab to open the analysis window again and re-run the simulation with the filter included. The Scenario Matrix shows a green square indicating that the filter successfully mitigated the interference. The Scenario Details also shows that the filter reduced the EMI margin to -20 dB.

N to 1 Combination Limit:

Total Channel Combinations: 1

Channel Combinations Analyzed: 1

Transmitters	EMI	Receivers	EMI
<ul style="list-style-type: none"> ▼ All ● -20.0 > <input checked="" type="checkbox"/> Tx-1 (Lo-VHF) ● -20.0 		<ul style="list-style-type: none"> ▼ All ● -20.0 > <input checked="" type="checkbox"/> Rx-0 (UHF) ● -20.0 	

Close the analysis window and rename the new result that was created in the Project Manager window to Result 2 – With filter. Both the results with and without the filter can now be accessed.